

Welding & Cutting Innovations Since 1948.

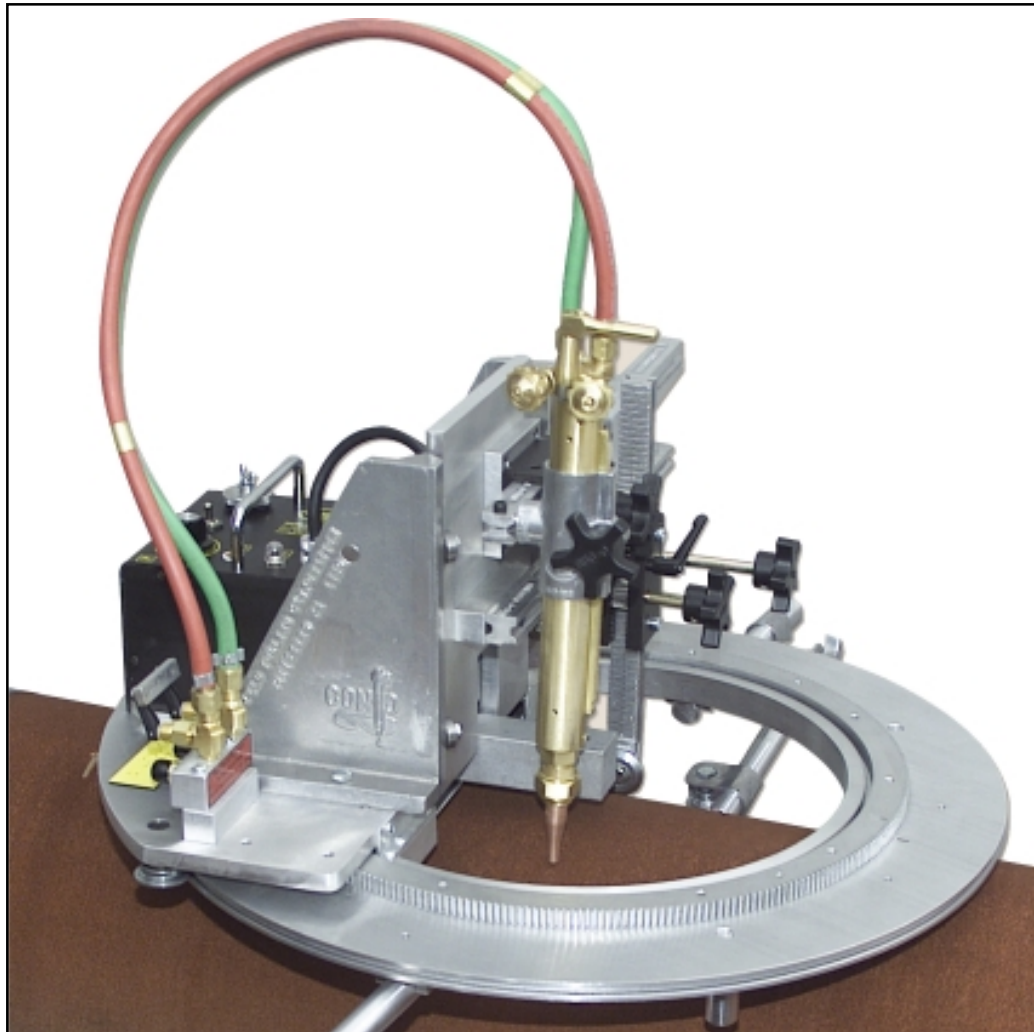

# CON-0 Precision Contour Saddle Cutter

CON-0 Precision Contour Burning and Beveling Machines Produce Elliptical Cuts and Bevels in Pipes and Cylinders.



The **CON-0** automatically follows symmetrical surfaces to produce smooth, accurate cuts and bevels. It is portable and easily taken to the work. The CON-0 locates from a center-punch mark and is set to a radius mark. Powerful permanent magnets stabilize the machine (two outrigger support kits are supplied with the CON-3 and CON-4, four outrigger support kits are supplied with the CON-5).

*PATENTS WORLDWIDE*



## **B U G - O   S Y S T E M S**

A DIVISION OF WELD TOOLING CORPORATION



3001 WEST CARSON STREET   PITTSBURGH, PENNSYLVANIA   USA 15204-1899  
PHONE: 1-800-245-3186   <http://www.bugo.com>   TELEFAX: 1-412-331-0383



# CON-O PRECISION CONTOUR SADDLE CUTTER

## Technical Data:

PART NUMBER:	POWER REQUIREMENT:	NET WEIGHT:	SHIPPING WEIGHT:
CON-3303	120 VAC/50-60-1	CON-3303, 3313, 3323	
CON-3313	42 VAC/50-60-1	65 lbs. (29.5 kg)	83 lbs. (37.6 kg)
CON-3323	240 VAC/50-60-1		
CON-4404	120 VAC/50-60-1	CON-4404, 4414, 4424	
CON-4414	42 VAC/50-60-1	80 lbs. (36.3)	98 lbs. (44.5 kg)
CON-4424	240 VAC/50-60-1		
CON-5505	120 VAC/50-60-1	CON-5505, 5515, 5525	
CON-5515	42 VAC/50-60-1	105 lbs. (47.7 kg)	130 lbs. (59.0 kg)
CON-5525	240 VAC/50-60-1		

## Capacities and Speed Ranges

	DIAMETER		DIAMETER	
	INCH	IPM	MM	MM/MIN
CON-3303	3	.4-8	75	10-210
	6	.8-16	150	20-420
	10	1.4-28	250	35-700
	14	2-39	350	50-1000
CON-4404	10	.9-18	250	23-460
	14	1.3-26	350	32-650
	18	1.7-33	450	42-840
	22	2-40	550	50-1000
CON-5505	18	1.3-25	450	32-640
	22	1.5-30	550	38-760
	26	1.8-37	650	45-900
	30	2-41	750	52-1050

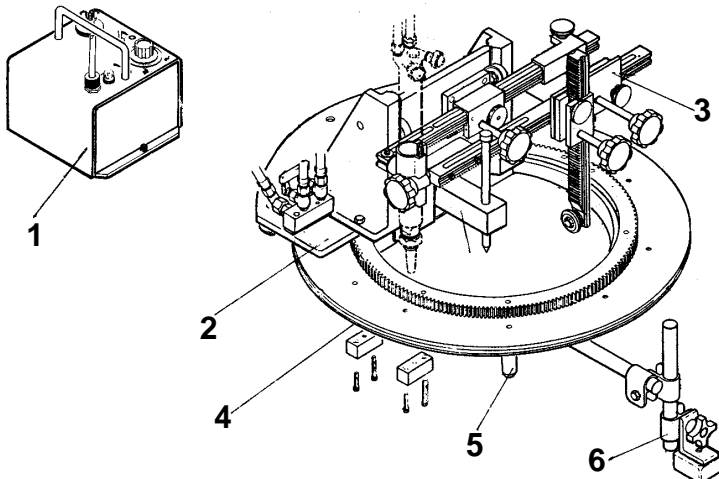

## IMPORTANT NOTICE

Saddle cut diameters should not exceed 2/3 the diameter of the pipe. The smallest size pipe that is practical is 12" (305 mm). (Example: 8" (203 mm) hole maximum on a 12" (305 mm) pipe). Maximum diameters practical will be reduced when bevel cuts are made. The above chart shows diameter for straight cuts.

## Dimensions:

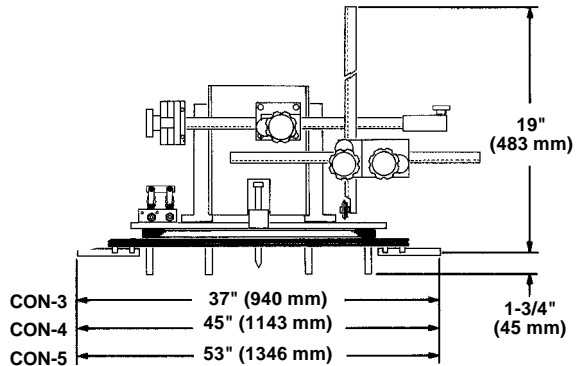
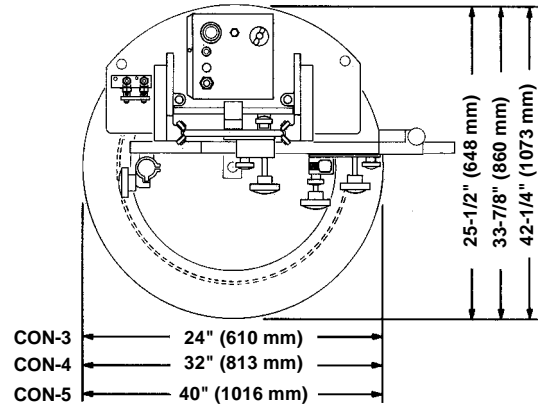

1. BUG-5100-F drive unit provides the power with a solid-state variable speed control.
2. CON-3040, CON-4040, and CON-5040, carriage insures accurate work paths by meshing firmly with the gear. A quick-acting manifold with a short connection hose, centering pin and counter-balanced floating plate, for torch mounting, are mounted on the carriage.
3. This combination of modules provides accurate positioning of the torch for saddle cuts and bevels. The guide wheel, diametrically opposite the torch tip, maintains accurate nozzle-to-work distance on symmetrically contoured vessels.
4. CON-3000, CON-4000, CON-5000 ring and gear assembly, with its perfectly round cut ring gear, makes every cut true.
5. Legs and alignment bars position machine on any symmetrical steel surface.
6. CON-1010 outrigger support kit.
7. Center locator with stainless steel center pin.

**NOTE: A cutting torch is not furnished with the machine unless specified separately.**